



Burger Hub- und Transportmittel GmbH
Distribution Deutschland

Junostraße 30 | 35745 Herborn-Burg

Telefon: +49 2772 9657-0

E-Mail: kontakt@bhtgmbh.de

www.bhtgmbh.de
www.hangcha-gabelstapler.de



Follow us on
Facebook



Follow us on
YouTube



Follow us on
WeChat



Download "Hangcha
Forklift" App



ISO45001:2018



ISO14001:2015



ISO9001:2015



HANGCHA trucks conform
to the European Safety
Requirements.

2024 VERSION 1.1 COPYRIGHT 2024/01

HANGCHA GROUP CO., LTD. reserves the right to make any changes without notice concerning colors, equipment, or specifications detailed in this brochure, or to discontinue individual models. The colors of trucks, delivered may differ slightly from those in brochures.



Mini Pallet Handler

with capacities of 1,500 to 2,000kg

The World of Hangcha
SINCE 1956



Mini Pallet Handler

The mini pallet handler is a new generation product developed by Hangcha for warehousing and logistics applications. Powered by a stable lead-acid battery and with high performance, comfortable, safe and reliable operations, as well as a low use cost, it is an ideal tool for loading, unloading and handling palletized goods in warehouses, supermarkets, workshops and homes.

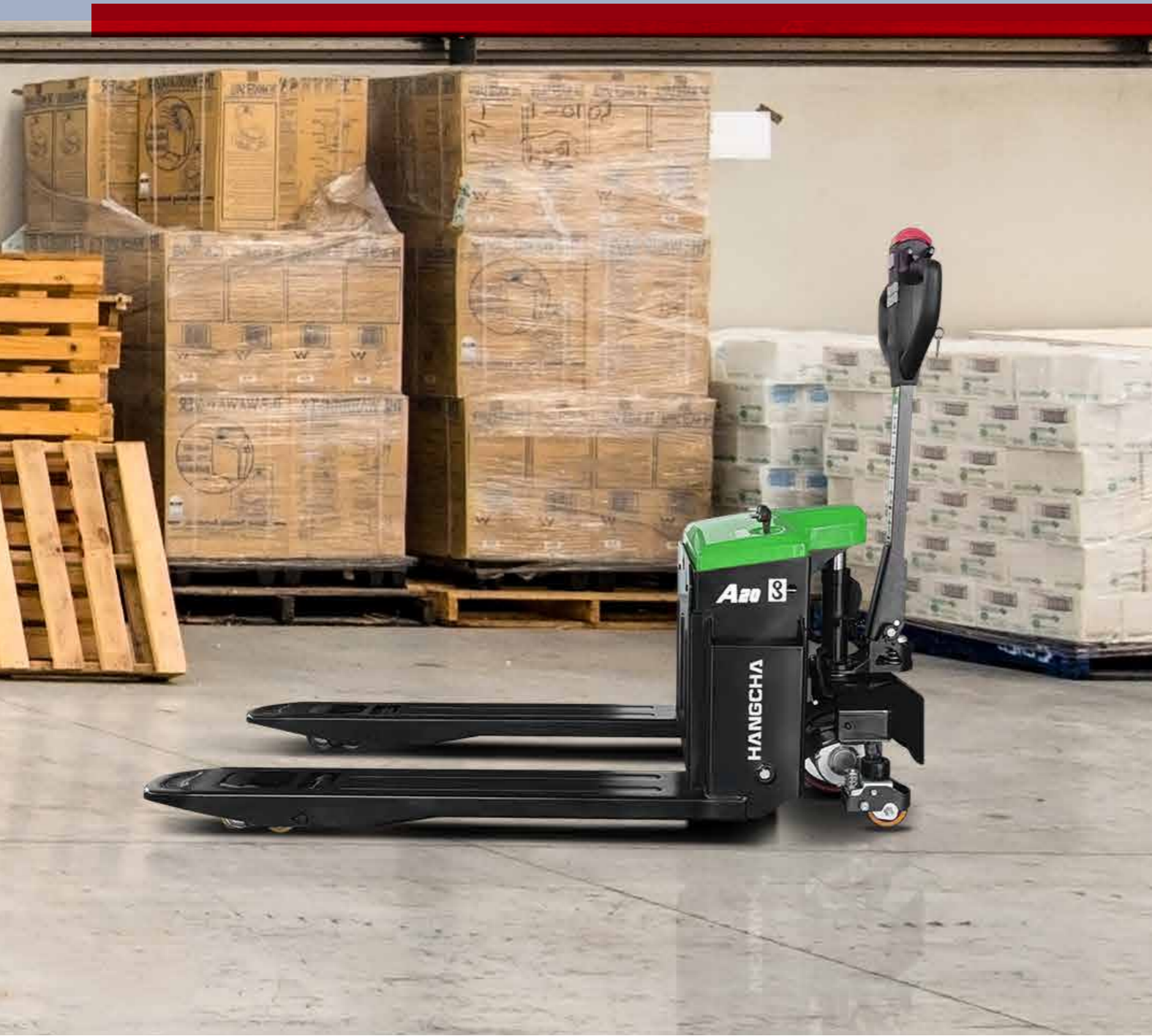

Exterior

- / The mini pallet handler adopts a specialized industrial exterior design. The vehicle has a smooth vivid profile, a compact shape and a fully ergonomic design, and follows the exterior design trend.
- / It is 90% made of steel plates that are molded by stamping, so the exterior is robust, durable and high-grade, and meets environmental protection requirements.

High performance

- / With high power and a rated load of 1.5-2 tons to meet the handling needs of most customers.
- / The 1.5t handler uses a DC permanent magnet brushed walking motor and a DC permanent magnet brushed control system.
- / The 2t handler uses a DC permanent magnet brushless walking motor and a DC permanent magnet brushless control system.
- / The vehicle has a regenerative braking function and provides protection to prevent sliding down a ramp.
- / All parts such as the motor controller, hydraulic pump station, switches, connectors, etc. are reliable products.

Reliability

- / The four-point design and two auxiliary wheels make steering safer, as well as more stable and reliable.
- / Optimized mast which is stable, reliable and subject to a small force.
- / The whole system uses domestic quality waterproof connectors, and all wires and cables have reliable protection, which greatly improves the reliability of the electrical system.
- / With a low noise and low vibration hydraulic power unit to enable stable and reliable lifting and descending.
- / The stamped fork with higher strength and impact resistance, and guided fork prongs, further improve operation efficiency.
- / The interlock switch is a non-contact proximity switch with high reliability.
- / The integrated iron wheel casing can protect the vehicle body from external impact well.

Maintenance

- / The battery indicator can duly prompt the user to charge.
- / Hood convenient to open, enabling a clear view of the components and easy maintenance of the truck.
- / With all spindles equipped with lubricated sleeves to facilitate maintenance and a long service life.
- / The joystick assembly can be removed separately, and thereby can be maintained and packed easily.



Operating handle



Cooling system



Steering wheel



Lifting cylinder

Comfort

- / With the reliable, compact and stylish modular joystick with internal parts that can be replaced separately, all operations can be completed with one hand.
- / The optimized body structure enables the forklift to have an excellent operating view.
- / Being compact, lightweight and flexible, it has a function of upright driving and can be operated very easily. It can be operated in narrow aisles, e.g., in a container.
- / With a guide device added, the fork provided for the standard configuration is 80mm in height and has prong tips inclined at 2 degrees to access the pallet (including the closed pallet) more easily.
- / Removed from the front, the lead-acid battery can be replaced easily and quickly, and meets the need of long operation.

Safety

- / With the functions of release braking, reversing braking and emergency braking to ensure safe driving.
- / Anti-roll back function to ensure safe operation.
- / Emergency reverse button on the tiller head able to effectively avoid harms to the driver in case of any emergency during backward driving.
- / With the dual protection by the electronic lifting limit and mechanical limit switches that are provided for the standard configuration, the impact caused by lifting to the top can be avoided and the safety of the goods can be ensured.

Standard Specification

- / DC permanent magnet brushless drive motor (2t)
- / DC permanent magnet brushless controller (2t)
- / Emergency shut-off switch
- / Battery level gauge
- / Polyurethane tire
- / DC permanent magnet brushed drive motor (1.5t)
- / DC permanent magnet brushed controller (1.5t)
- / Fork interval: 560mm
- / Electronic lifting limit
- / Fork length: 1150mm
- / Non-contact interlock switch
- / Modular joystick
- / Electric horn
- / Stable quality lead-acid battery
- / Slow upright driving
- / Guide device-equipped fork for closed pallets
- / Double load wheels
- / Automatic hibernation function

Options

- / A full range of prong lengths
- / A full range of prong intervals
- / Single load wheel
- / Code lock
- / Fork surface from the ground: 75mm

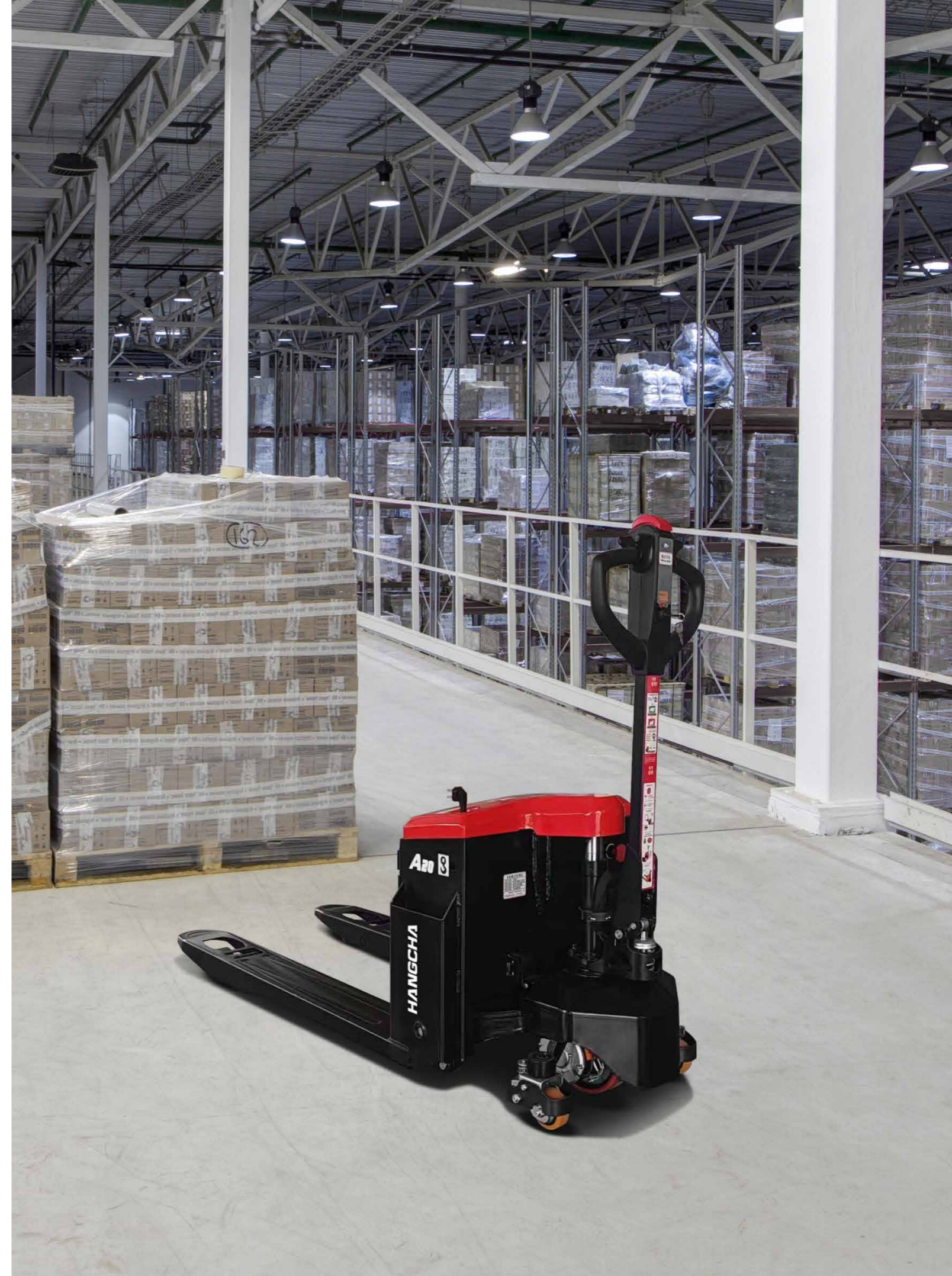

Mini Pallet Handler Specification

		HANGCHA GROUP CO.,LTD.					
Distinguishing mark	1.1	Manufacturer					
	1.2	Manufacturer's type designation	CBD15-WD	CBD15-WD-I	CBD20-WD	CBD20-WD-I	
	1.3	Drive: electric (battery type, mains, ...), diesel, petrol, fuel gas	Electric	Electric	Electric	Electric	
	1.4	Operator type: hand, pedestrian, standing, seated, order-picker	Pedestrian	Pedestrian	Pedestrian	Pedestrian	
	1.5	Rated capacity/rated load	kg	1500	1500	2000	2000
	1.6	Load centre distance	c (mm)	600	600	600	600
	1.8	Load distance, centre of drive axle to fork	x (mm)	905	905	905	905
	1.9	Wheelbase	y (mm)	1175/1248	1175/1248	1175/1248	1175/1248
	Weight	2.1	Service weight	kg	220/227	180/187	225/232
Tyres, chassis	3.1	Tyres: solid rubber, superelastic, pneumatic, polyurethane		PU	PU	PU	PU
	3.2	Tyre size, front		φ210x70	φ210x70	φ210x70	φ210x70
	3.3	Tyre size, rear		φ80x64	φ80x64	φ80x64	φ80x64
	3.5	Wheels, number front/rear (* = driven wheels)		1x/4	1x/4	1x2/4	1x2/4
	3.6	Tread, front	b10(mm)	/	/	410	410
	3.7	Tread, rear	b11(mm)	400/520	400/520	400/520	400/520
	Dimensions	4.4	Lift	h3(mm)	120	120	120
4.9		Height drawbar in driving position min./max.	h14(mm)	650/1255	650/1255	650/1255	650/1255
4.15		Height, lowered	h13(mm)	80	80	80	80
4.19		Overall length	l1(mm)	1700	1700	1700	1700
4.21		Overall width	b1/b2(mm)	590/680	590/680	590/680	590/680
4.22		Fork dimensions DIN ISO 2331	s/e/l(mm)	50/160/1150	50/160/1150	50/160/1150	50/160/1150
4.25		Fork spread	b5(mm)	560/680	560/680	560/680	560/680
4.32		Ground clearance, centre of wheelbase	m2(mm)	30	30	30	30
4.34.1		Aisle width for pallets 1000 × 1200 crossways	As1(mm)	1553①②	1553①②	1553①②	1553①②
4.34.2		Aisle width for pallets 800 × 1200 lengthways	As2(mm)	1753①③	1753①③	1753①③	1753①③
4.35	Turning radius	Wa(mm)	1374①	1374①	1374①	1374①	
Performance data	5.1	Travel speed, laden/unladen	km/h	4.5/4.8	4.5/4.8	4.5/4.8	4.5/4.8
	5.2	Lift speed, laden/unladen	m/s	0.045/0.055	0.045/0.055	0.045/0.055	0.045/0.055
	5.3	Lowering speed, laden/unladen	m/s	0.06/0.04	0.05/0.04	0.06/0.04	0.05/0.04
	5.8	Max. gradeability, laden/unladen	%	6/16	6/16	6/16	6/16
	5.10	Service brake		Electromagnetic brake	Electromagnetic brake	Electromagnetic brake	Electromagnetic brake
Electric Engine	6.1	Drive motor rating S2 60 min	kW	0.75	0.75	0.9	0.9
	6.2	Lift motor rating at S3 15 %	kW	0.8	0.8	0.8	0.8
	6.4	Battery voltage/nominal capacity	(V)/(Ah)or kWh	24/85	24/40	48 /56	48/20
	6.5	Battery weight	kg	24x2	11	13.2x4	11

Note: ① Fork lowering +76mm; ② According to VD12198 standard +631mm; ③ According to VD12198 standard +323mm

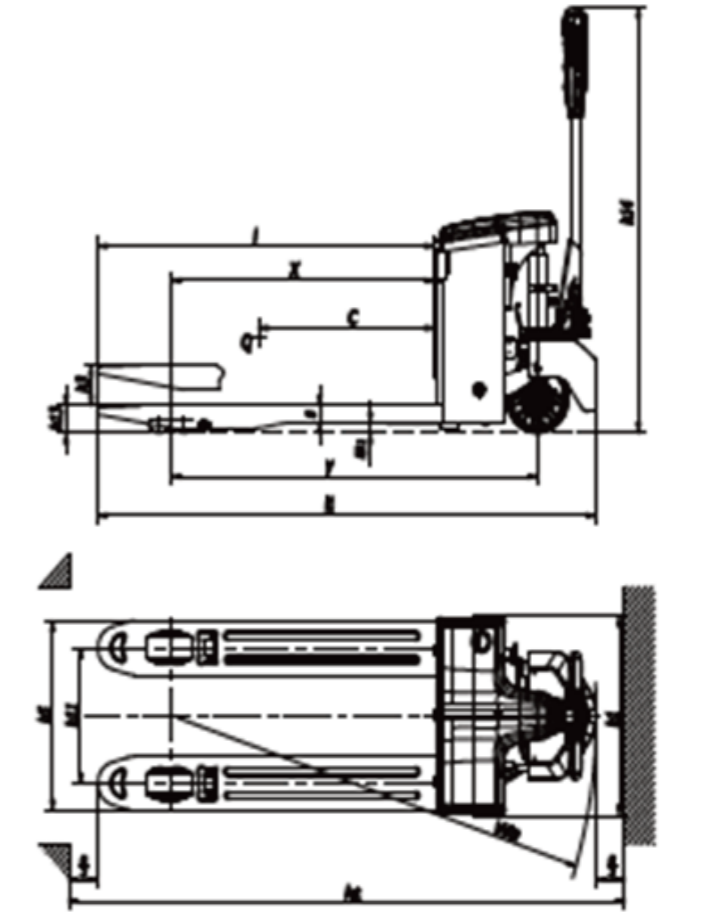

1.5t handler

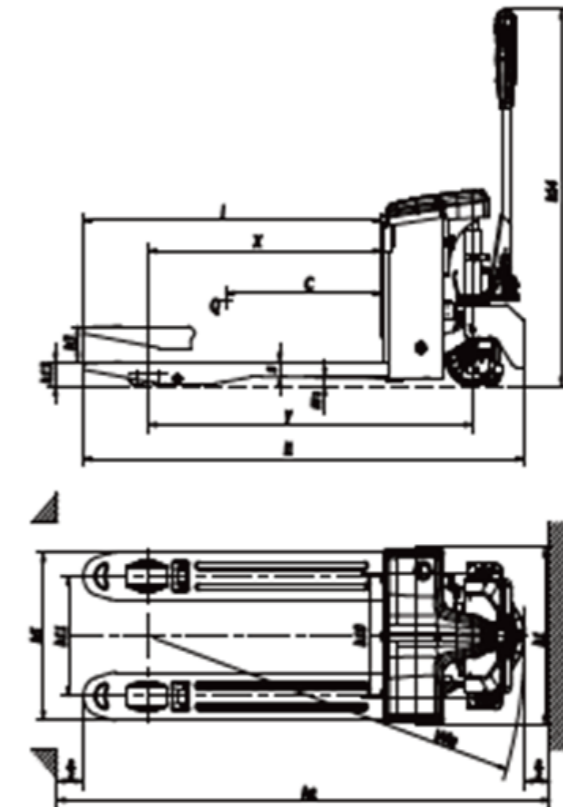

2.0t handler